



IT170

TUMBLE DRYER

FOR ON-PREMISES LAUNDRY APPLICATIONS

**INDUSTRIAL
BY DESIGN**



Over-dry Prevention Technology (OPT) offers unmatched levels of accuracy, resulting in a pinpoint dryness reading throughout the entire load. Specialized sensors located within the lifters are connected to our revolutionary rotary transfer switch to determine the exact moment your linens are dry, which helps eliminate overdrying and increases throughput. Additionally, it reduces utility consumption, saving hundreds of dollars a year in unnecessary energy costs.

OPT is available in IPSO's OPTimum™ control, which offers 30 programmable drying cycles for greater operating efficiency and is easy to train staff to operate. It also delivers flexibility with simple customization of cycles. The OPTimum control is available on all IPSO-tumblers.

Unmatched Industrial Reliability

- Large cylinder
 - Allows free air movement
 - Short drying cycles
- Standard galvanized drum
 - Oval drum holes preventing damage from standard drywall screws
- High performance heater box
 - Incoming air is preheated by the radiant heat from the stove top
 - Increased energy efficiency
 - Faster drying times
 - More comfortable operating environment
- High performance heat system
 - Immediate ignition of the burner
 - Quick & efficient reach of desired temperature
 - Reduced drying times
 - Energy-saving
- Radial airflow
 - Drum perforations over the entire surface
 - High production
 - Pulley drive system
- Reversing
 - Prevents tangling of the linen
- CARE = Combustion Auto Response EquippedA response to laundry combustion
 - Prevents early laundry fire by constantly monitoring the temperature in the drum
 - In case of excessive temperature, the linen is sprayed with water

Easy to Use Simplicity

- Dual Digital Timer
 - Economic control
 - Easy to use
 - Select time, temperature and cooling time
- OPTimum control
 - Easy to operate
 - Easy to program
 - 30 programmable cycles
 - 3 cycle types
 - Time Dry: programmable time and temperature
 - Auto Dry: 11 programmable automatic dryness levels and programmable temperature
 - Moisture Dry: will dry to the programmed moisture level at programmed temperature

IT170

Technical specifications

| | |
|--------------------------------------|----------------|
| Filling ratio (20:1) (lb) | 155 |
| Dry weight capacity (lb) | 170 |
| Cylinder | |
| Volume (cu ft) | 49.7 |
| Diameter (inch) | 50.75 |
| Depth (inch) | 42.5 |
| Door opening diameter (inch) | 26.89 |
| Temperature min (°F) | 100.4 |
| Temperature max (°F) | 190.4 |
| Power motor reversing | |
| Cylinder (hp) | 0.75 |
| Fan (hp) | 3 |
| Exhaust flow rate (60 Hz) (cfm) | 2450 |
| Diameter (inch) | 12 |
| Power | |
| Gas heating (Btu/h) | 395,000 |
| Gas heating (kcal) | 99,500 |
| Steam heating | |
| @ 6.9 bar (bhp) / (Btu/h) | 18.8 / 648,000 |
| @ 1.0 bar (bhp) / (Btu/h) | 12.6 / 433,000 |
| Steam connection inlet | 3/4" |
| Steam connection outlet | 1" |
| Gas connection | 1" |
| Gas connection - Pressure NG/LP (mb) | 20 / 28.37 |
| Std Pkg Ship Dim. (HxWxD) (inch) | 99 x 58 x 74.5 |
| Noise level (dBA) | 66 |
| Weight | |
| Gross (Gas/elec) (lb) | 1667 |
| Gross (Gas) (lb) | |
| Gross (Steam) (lb) | 1776 |
| Net (Gas/elec) (lb) | 1575 |
| Net (Gas) (lb) | |
| Net (Steam) (lb) | 1675 |
| C.A.R.E. | optional |

Type of heating

| | |
|--------------------------------------|-------|
| Steam / gas heating 200-208/240/60/3 | 13.5A |
| Steam / gas heating 460-480/60/3 | 6.7A |
| Steam heating 440/60/3 | 6.4A |

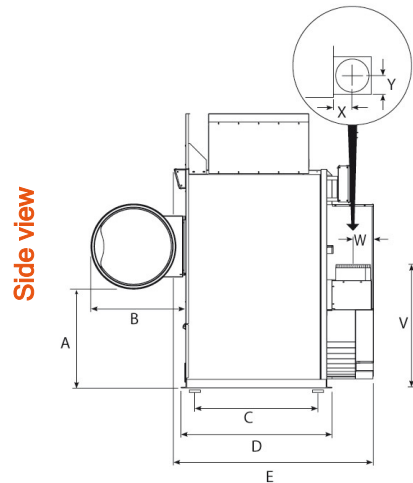
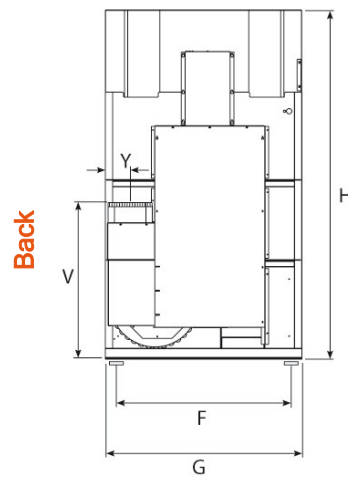

A 33.86 inch B 32.52 inch C 50.75 inch D 51.73 inch E 68.86 inch F 52.13 inch G 53.11 inch H 94.02 inch V 42.36 inch W 6.73 inch X 8.74 inch Y 7.01 inch

All specifications subject to change without notice